



Report

US \$44.99

**2020 Land Rover
Range Rover
Evoque S**

33,589 mi
| **VIN:**
SALZJ2FX7LH107971

4 Door Wagon/Sport
Utility
| 2.0L I4 F DOHC 16V
| Gasoline
| All wheel drive

CARFAX HAS THE MOST
ACCIDENT & DAMAGE
INFORMATION



BRANDED TITLE

Salvage

CARFAX VALUE **\$16,370**

8 Service
History
Records

2 Previous
Owners

Types of
Owners:
 Personal
Lease,
Personal

Last
Owned in
Virginia

27
Detailed
Records
Available

This CARFAX Vehicle History Report is based only on information supplied to CARFAX and available as of 4/29/26 at 6:32:28 AM (CDT). Other information about this vehicle, including problems, may not have been reported to CARFAX. Use this report as one important tool, along with a vehicle inspection and test drive, to make a better decision about your next used car.



Accident / Damage History

Not all accidents / issues are reported to CARFAX

Event 1

09/05/2022

Accident reported: minor damage

Damage Severity Scale



MinorModerateSevere

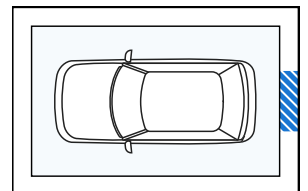

Event 2

03/09/2026

Accident reported with another motor vehicle

- Severe damage reported
- Vehicle towed
- Airbags did not deploy

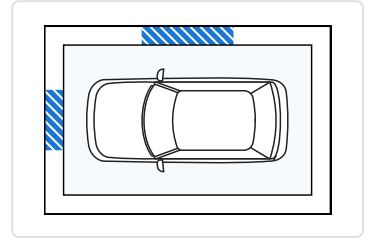

Event 3

03/09/2026

TOTAL LOSS VEHICLE

- Vehicle declared a total loss by an insurance company



Recent Service Highlights

Key services performed in the last 12 months

Service	Comments	Date
Oil	✓ Oil and filter changed	07/05/2025

This car has been recently serviced. That's a good thing!



History-Based Value Report

\$16,370

CARFAX Retail Value

History events affecting this vehicle's value

- Service History
- Personal Vehicle
- Salvage Brand



Additional History

Not all accidents / issues are reported to CARFAX

Owner 1

Owner 2

Total Loss

Total Loss Reported: 03/09/2026 and 04/22/2026.

No Issues Reported

Total Loss Reported

Structural Damage CARFAX recommends that you have this vehicle inspected by a collision repair specialist.	<input checked="" type="checkbox"/> No Issues Reported	<input checked="" type="checkbox"/> No Issues Reported
Airbag Deployment No airbag deployment reported to CARFAX.	<input checked="" type="checkbox"/> No Issues Reported	<input checked="" type="checkbox"/> No Issues Reported
Odometer Check No indication of an odometer rollback.	<input checked="" type="checkbox"/> No Issues Indicated	<input checked="" type="checkbox"/> No Issues Indicated
Accident / Damage DMV title problems reported. Accidents reported: 09/05/2022 and 03/09/2026.	Accident Reported	Severe Damage
Manufacturer Recall No open recalls reported to CARFAX.	<input checked="" type="checkbox"/> No Recalls Reported	<input checked="" type="checkbox"/> No Recalls Reported
Basic Warranty Original manufacturer warranty likely voided by manufacturer.	<input checked="" type="checkbox"/> Warranty Active	Warranty Voided





 Title History	Owner 1	Owner 2
Damage Brands Salvage Junk Rebuilt Fire Flood Hail Lemon	No Problem	Alert! Problem Found
Odometer Brands Not Actual Mileage Exceeds Mechanical Limits	No Problem	No Problem



ALERT! - Severe problems were reported by a state Department of Motor Vehicles (DMV). This vehicle does not qualify for the CARFAX Buyback Guarantee.



 Ownership History The number of owners is estimated	Owner 1	Owner 2
Year purchased	2020	2024
Type of owner	Personal Lease	Personal
Estimated length of ownership	3 yrs. 8 mo.	1 yr. 4 mo.
Owned in the following states/provinces	New Jersey	Virginia
Estimated miles driven per year	6,217/yr	7,368/yr
Last reported odometer reading	23,410	33,589

 Detailed History	
 Owner 1 Purchased: 2020	Personal Lease Vehicle 6,217 mi/yr

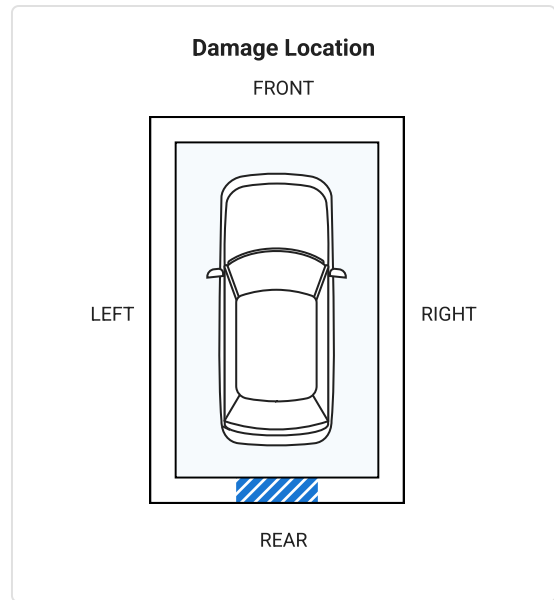
Date	Mileage	Source	Comments
11/09/2020	7	New York Inspection Station	Passed safety inspection - Emissions inspection performed
11/18/2020	19	Jaguar Land Rover Manhattan New York, NY 212-549-2200 jlrmanhattan.com ★ 4.7 / 5.0 528 Verified Reviews ❤️ 5,330 Customer Favorites	 Vehicle serviced - Pre-delivery inspection completed - Brakes checked - Safety inspection performed - Vehicle washed/detailed
12/15/2020		New Jersey Motor Vehicle Dept. West Long Branch, NJ	Registration issued or renewed - Titled or registered as personal lease vehicle - Vehicle color noted as White
01/04/2021		New Jersey Motor Vehicle Dept. Fort Worth, TX Title #JC20210040055	Title issued or updated - First owner reported - Vehicle color noted as White
07/22/2021		Land Rover Monmouth EATONTOWN, NJ 732-869-2500 landrovermonmouth.com ★ 4.6 / 5.0 469 Verified Reviews ❤️ 5,615 Customer Favorites	 Inspection performed - Alignment checked
08/11/2021	6,168	Land Rover Monmouth Eatontown, NJ 732-869-2500 landrovermonmouth.com ★ 4.6 / 5.0 469 Verified Reviews ❤️ 5,615 Customer Favorites	 Vehicle serviced - Maintenance inspection completed - Exterior trim checked
09/05/2022		Damage Report	Accident reported: minor damage - Damage to rear <div data-bbox="837 1668 1380 2016"> <p style="text-align: center;">Damage Severity Scale</p>  <p style="text-align: center;">Minor Moderate Severe</p> </div>



CARFAX HAS THE MOST ACCIDENT & DAMAGE INFORMATION



09/05/2023	18,654	Land Rover Monmouth Eatontown, NJ 732-869-2500 landrovermonmouth.com ★ 4.6 / 5.0 469 Verified Reviews ❤️ 5,615 Customer Favorites	 Vehicle serviced - Maintenance inspection completed - A/C and heating system checked - Oil and filter changed
10/27/2023	19,520	Land Rover Monmouth Eatontown, NJ 732-869-2500 landrovermonmouth.com ★ 4.6 / 5.0 469 Verified Reviews ❤️ 5,615 Customer Favorites	 Vehicle serviced - Pre-delivery inspection completed - Maintenance inspection completed
04/16/2024		New Jersey Motor Vehicle Dept. West Long Branch, NJ	Registration issued or renewed - Vehicle color noted as White
05/09/2024	21,187	AAA Lawrenceville Car Care Lawrenceville, NJ 609-419-1704 ★ 4.5 / 5.0 212 Verified Reviews ❤️ 11 Customer Favorites	 Vehicle serviced - Alignment checked - Tire(s) replaced
08/24/2024		Online Listing	Vehicle offered for sale
09/16/2024	23,354	Financial Company	Vehicle sold
09/18/2024		Alpha Motorsports Manassas Manassas, VA	Vehicle offered for sale

703-763-4675
alphamotorsport.net/
★ 3.3 / 5.0
18 Verified Reviews

10/09/2024	23,410	Virginia Inspection Station	Passed safety inspection
11/08/2024		Virginia Motor Vehicle Dept.	Vehicle purchase reported
11/12/2024		Virginia Inspection Station	Passed emissions inspection

 **Owner 2**
Purchased: 2024

Personal Vehicle
7,368 mi/yr

Date	Mileage	Source	Comments
12/05/2024	23,435	Virginia Motor Vehicle Dept. Vienna, VA	Title issued or updated - Title or registration issued - New owner reported - Loan or lien reported
02/25/2025	25,164	Virginia Tire & Auto of Vienna Vienna, VA 703-537-5660 https://vatire.com/stores/virginia-tire-auto-of-vienna/ ★ 4.6 / 5.0 309 Verified Reviews ❤️ 11 Customer Favorites	 Vehicle serviced - Maintenance inspection completed - Fluids checked - Tire repaired
07/05/2025	28,034	Jiffy Lube Vienna, VA 703-242-0691 stcjiffylube.com/ ★ 4.8 / 5.0 29 Verified Reviews ❤️ 25 Customer Favorites	 Vehicle serviced - Oil and filter changed
11/28/2025	32,000	Virginia Inspection Station	Passed emissions inspection
11/28/2025	32,104	Virginia Inspection Station	Passed safety inspection
12/09/2025		Virginia Motor Vehicle Dept. Vienna, VA	Registration issued or renewed - Loan or lien reported
03/09/2026		Damage Report	 Accident reported with another motor vehicle - Damage to right side - Damage to front - Severe damage reported

- Vehicle towed
- Airbags did not deploy

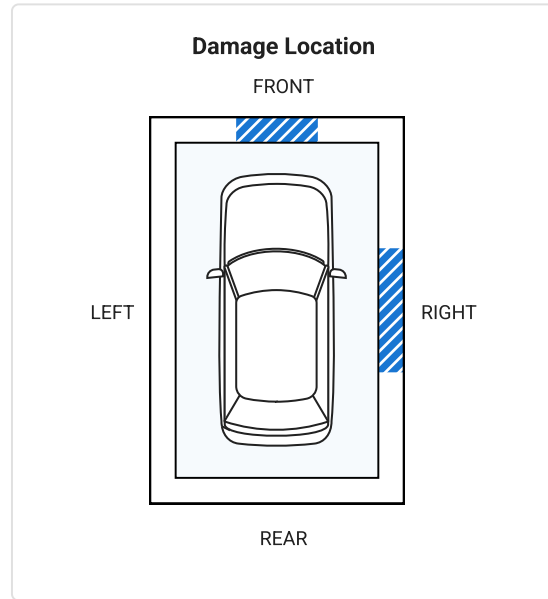

CARFAX HAS THE MOST ACCIDENT & DAMAGE INFORMATION

03/09/2026

Damage Report



TOTAL LOSS VEHICLE

- Vehicle declared a total loss by an insurance company

There are many reasons an insurance company will declare a vehicle a total loss. Have this vehicle inspected by a qualified technician before you buy. [Learn More](#)

04/22/2026

Virginia
Motor Vehicle Dept.

Title or registration issued to insurance company

04/22/2026

33,589

Virginia
Motor Vehicle Dept.
Chantilly, VA



TOTAL LOSS VEHICLE

- Vehicle purchase reported
- SALVAGE TITLE/CERTIFICATE ISSUED

Have Questions? Consumers, please visit our Help Center at www.carfax.com. Dealers or Subscribers, please visit our Help Center at www.carfaxonline.com.



Glossary

Accident Indicator

CARFAX receives information about accidents in all 50 states, the District of Columbia and Canada.

Not every accident is reported to CARFAX. As details about the accident become available, those additional details are added to the CARFAX Vehicle History Report. CARFAX recommends that you have this vehicle inspected by a qualified mechanic.

- According to the National Safety Council, Injury Facts, 2021 edition, 5% of the 276 million registered vehicles in the U.S. were involved in an accident in 2019. Over 77% of these were considered minor or moderate.
- This CARFAX Vehicle History Report is based only on information supplied to CARFAX and available as of 4/29/26 at 6:32:28 AM (CDT). Other information about this vehicle, including problems, may not have been reported to

CARFAX. Use this report as one important tool, along with a vehicle inspection and test drive, to make a better decision about your next used car.

Damage Indicator

Damage can be a result of many different types of events. Examples include contact with objects (other cars, trees, traffic signs, road debris, etc), vandalism, or weather-related events. Not every damage event is reported to CARFAX. As details about the damage event become available, those additional details are added to the CARFAX Vehicle History Report. CARFAX recommends that you have this vehicle inspected by a qualified mechanic.

- This CARFAX Vehicle History Report is based only on information supplied to CARFAX and available as of 4/29/26 at 6:32:28 AM (CDT). Other information about this vehicle, including problems, may not have been reported to CARFAX. Use this report as one important tool, along with a vehicle inspection and test drive, to make a better decision about your next used car.

Damage Severity

Damage events result in one of the following severity levels:

- Minor: Generally, minor damage is cosmetic (including dents or scratches), may only require reconditioning, and typically does not compromise a vehicle's operation and/or safety.
- Moderate: Moderate damage may affect multiple components of the vehicle and may impair the vehicle's operation and/or safety.
- Severe: Severe damage usually affects multiple components of the vehicle and is likely to compromise the vehicle's operation and/or safety.

CARFAX recommends getting a pre-purchase inspection at a certified collision repair facility.

First Owner

When the first owner(s) obtains a title from a Department of Motor Vehicles as proof of ownership.

New Owner Reported

When a vehicle is sold to a new owner, the Title must be transferred to the new owner(s) at a Department of Motor Vehicles.

Ownership History

CARFAX defines an owner as an individual or business that possesses and uses a vehicle. Not all title transactions represent changes in ownership. To provide estimated number of owners, CARFAX proprietary technology analyzes all the events in a vehicle history. Estimated ownership is available for vehicles manufactured after 1991 and titled solely in the US including Puerto Rico. Dealers sometimes opt to take ownership of a vehicle and are required to in the following states: Maine, Massachusetts, New Jersey, Ohio, Oklahoma, Pennsylvania and South Dakota. Please consider this as you review a vehicle's estimated ownership history.

Salvage Title

A Salvage Title is issued on a vehicle damaged to the extent that the cost of repairing the vehicle exceeds approximately 75% of its pre-damage value. This damage threshold may vary by state. Some states treat Junk titles the same as Salvage but the majority use this title to indicate that a vehicle is not road worthy and cannot be titled again in that state. The following eleven states also use Salvage titles to identify stolen vehicles - AZ, FL, GA, IL, MD, MN, NJ, NM, NY, OK and OR.

Title Issued

A state issues a title to provide a vehicle owner with proof of ownership. Each title has a unique number. Each title or registration record on a CARFAX report does not necessarily indicate a change in ownership. In Canada, a registration and bill of sale are used as proof of ownership.

Total Loss Vehicle

An insurance or fleet company declares a vehicle a total loss when a claim exceeds approximately 75% of its pre-damage value or if the vehicle is stolen and not recovered. This damage threshold varies by company. These companies typically take possession and obtain the title. Not all total loss vehicles result in a DMV-reported branded title. This may occur when an insurance company's definition of a total loss is different than the state DMV's definition for a branded title or when the owner of the vehicle is a self-insured company, like a fleet or rental company.

Follow Us:  facebook.com/CARFAX  [@CARFAXinc](https://twitter.com/CARFAXinc)  About CARFAX

CARFAX DEPENDS ON ITS SOURCES FOR THE ACCURACY AND RELIABILITY OF ITS INFORMATION. THEREFORE, NO RESPONSIBILITY IS ASSUMED BY CARFAX OR ITS AGENTS FOR ERRORS OR OMISSIONS IN THIS REPORT. CARFAX FURTHER EXPRESSLY DISCLAIMS ALL WARRANTIES, EXPRESS OR IMPLIED, INCLUDING ANY IMPLIED WARRANTIES OF MERCHANTABILITY OR FITNESS FOR A PARTICULAR PURPOSE.

© 2026 CARFAX, Inc., part of S&P Global. All rights reserved.
4/29/26 6:32:28 AM (CDT)

I have reviewed and received a copy of the CARFAX Vehicle History Report for this 2020 LAND ROVER RANGE ROVER EVOQUE vehicle (VIN: SALZJ2FX7LH107971), which is based on information supplied to CARFAX and available as of

4/29/26 at 7:32 AM (EDT).

Customer Signature

Date

Dealer Signature

Date