



Report

2023 Mazda CX-50 2.5 S Premium Plus

32,510 mi | VIN: 7MMVABEM4PN101520

CARFAX HAS THE MOST ACCIDENT & DAMAGE INFORMATION



BRANDED TITLE

Salvage

Regular Oil Changes

14 Service History Records

CARFAX 1-Owner Vehicle

Personal Vehicle

Last Owned in California



Accident / Damage History

Not all accidents / issues are reported to CARFAX

Event 1

07/30/2025

Accident reported: minor damage

- Vehicle involved in a rear-end collision with another motor vehicle
- Airbags did not deploy

Damage Severity Scale

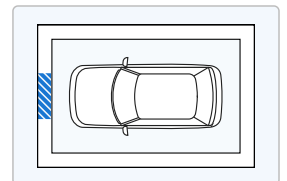
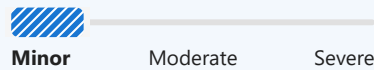

Event 2

04/01/2026

TOTAL LOSS VEHICLE

- Vehicle declared a total loss by an insurance company
- Collision damage reported

Event 3

05/19/2026

Damage reported: minor to moderate damage

Damage Severity Scale

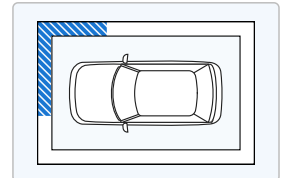

CARFAX Additional History Not all accidents / issues are reported to CARFAX	Owner 1
Total Loss Total Loss Reported: 04/01/2026.	Total Loss Reported
Structural Damage CARFAX recommends that you have this vehicle inspected by a collision repair specialist.	<input checked="" type="checkbox"/> No Issues Reported
Airbag Deployment No airbag deployment reported to CARFAX.	<input checked="" type="checkbox"/> No Issues Reported
Odometer Check No indication of an odometer rollback.	<input checked="" type="checkbox"/> No Issues Indicated
Accident / Damage DMV title problems reported. Accidents reported: 07/30/2025 and 04/01/2026. Damage reported: 05/19/2026.	Severe Damage
Manufacturer Recall No open recalls reported to CARFAX.	<input checked="" type="checkbox"/> No Recalls Reported
Basic Warranty Original manufacturer warranty likely voided by manufacturer.	Warranty Voided

CARFAX Title History	Owner 1
Damage Brands Salvage Junk Rebuilt Fire Flood Hail Lemon	Alert! Problem Found
Odometer Brands Not Actual Mileage Exceeds Mechanical Limits	No Problem
ALERT! - Severe problems were reported by a state Department of Motor Vehicles (DMV). This vehicle does not qualify for the CARFAX Buyback Guarantee.	

CARFAX Ownership History The number of owners is estimated	Owner 1
Year purchased	2022
Type of owner	Personal
Estimated length of ownership	4 years
Owned in the following states/provinces	California
Estimated miles driven per year	9,315/yr
Last reported odometer reading	32,510

CARFAX Detailed History			
Owner 1 Purchased: 2022		Personal Vehicle 9,315 mi/yr	
Date	Mileage	Source	Comments
03/30/2022		Mazda Motor of America, Inc.	Vehicle manufactured and shipped to original dealer Original Window Sticker

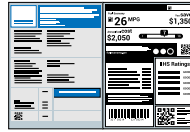

04/21/2022	6	Mazda of Orange Orange, CA 866-271-0599 mazdaoforange.com ★ 4.7 / 5.0 535 Verified Reviews ♥ 8,058 Customer Favorites		Vehicle offered for sale
04/21/2022		Mazda of Orange Orange, CA 866-271-0599 mazdaoforange.com ★ 4.7 / 5.0 535 Verified Reviews ♥ 8,058 Customer Favorites		Vehicle serviced -Pre-delivery inspection completed -Battery/charging system checked -Battery serviced
05/05/2022	7	Mazda of Orange Orange, CA 866-271-0599 mazdaoforange.com ★ 4.7 / 5.0 535 Verified Reviews ♥ 8,058 Customer Favorites		Vehicle serviced
05/27/2022		Mazda of Orange Orange, CA 866-271-0599 mazdaoforange.com ★ 4.7 / 5.0 535 Verified Reviews ♥ 8,058 Customer Favorites		Vehicle sold
05/31/2022	10	Mazda of Orange Orange, CA 866-271-0599 mazdaoforange.com ★ 4.7 / 5.0 535 Verified Reviews ♥ 8,058 Customer Favorites		Vehicle serviced
06/01/2022	22	California Motor Vehicle Dept. Anaheim, CA		Title issued or updated -First owner reported -Titled or registered as personal vehicle -Loan or lien reported
07/01/2022	871	Pep Boys Anaheim, CA 714-974-0105 pepboys.com ★ 4.5 / 5.0 276 Verified Reviews ♥ 207 Customer Favorites		Vehicle serviced -Tire(s) balanced -Tire(s) mounted
03/02/2023	6,499	Mazda of Orange Orange, CA 866-271-0599 mazdaoforange.com ★ 4.7 / 5.0 535 Verified Reviews ♥ 8,058 Customer Favorites		Vehicle serviced -Maintenance inspection completed -Oil and filter changed
03/22/2023	7,060	Pep Boys Anaheim, CA		Vehicle serviced -Maintenance inspection completed

714-974-0105
pepboys.com
★ 4.5 / 5.0 276 Verified Reviews
♥ 207 Customer Favorites

-Tire(s) balanced
-Tire(s) mounted

04/01/2023

Pep Boys
Anaheim, CA
714-974-0105
pepboys.com
★ 4.5 / 5.0 276 Verified Reviews
♥ 207 Customer Favorites



Vehicle serviced
-Maintenance inspection completed
-Tire(s) balanced
-Tire(s) mounted

08/29/2023

Mazda of Orange
Orange, CA
866-271-0599
mazdaoforange.com
★ 4.7 / 5.0 535 Verified Reviews
♥ 8,058 Customer Favorites



Vehicle serviced
-Maintenance inspection completed

09/23/2023

12,313

Mazda of Orange
Orange, CA
866-271-0599
mazdaoforange.com
★ 4.7 / 5.0 535 Verified Reviews
♥ 8,058 Customer Favorites



Vehicle serviced
-Maintenance inspection completed
-Battery/charging system checked
-Brakes checked
-Oil and filter changed

04/03/2024

17,337

Mazda of Orange
Orange, CA
866-271-0599
mazdaoforange.com
★ 4.7 / 5.0 535 Verified Reviews
♥ 8,058 Customer Favorites



Vehicle serviced
-Maintenance inspection completed
-Air filter replaced
-Battery/charging system checked
-Brakes checked
-Oil and filter changed

07/22/2024

20,269

Mazda of Orange
Orange, CA
866-271-0599
mazdaoforange.com
★ 4.7 / 5.0 535 Verified Reviews
♥ 8,058 Customer Favorites



Vehicle serviced
-Maintenance inspection completed

05/30/2025

26,923

Mazda of Orange
Orange, CA
866-271-0599
mazdaoforange.com
★ 4.7 / 5.0 535 Verified Reviews
♥ 8,058 Customer Favorites



Vehicle serviced
-Maintenance inspection completed
-Battery/charging system checked
-Brakes checked
-Brake rotor(s) resurfaced
-Front brake pads replaced
-Front brake rotor(s) resurfaced
-Front brakes replaced
-Oil and filter changed
-Rear brake pads replaced
-Rear brake rotor(s) resurfaced

07/30/2025

Damage Report





Accident reported: minor damage
-Vehicle involved in a rear-end collision with another motor vehicle
-Damage to front
-Airbags did not deploy

Damage Severity Scale

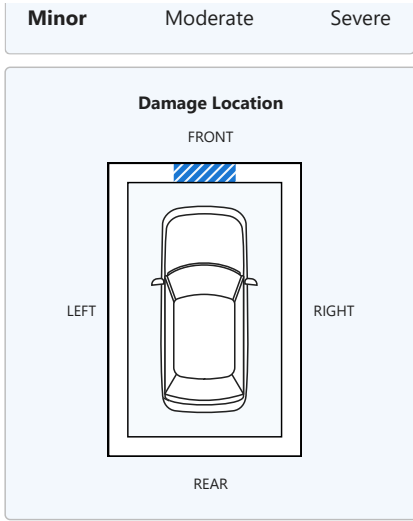

CARFAX HAS THE MOST ACCIDENT & DAMAGE INFORMATION

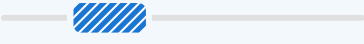

<p>09/14/2025</p>	<p>31,119</p>	<p>University Tire & Auto Service Los Angeles, CA 323-733-1236 universitytirecenter.com/ ★ 4.6 / 5.0 79 Verified Reviews ♥ 45 Customer Favorites</p>	<p> Vehicle serviced -One tire balanced -One tire mounted</p>
<p>11/25/2025</p>	<p>32,510</p>	<p>University Tire & Auto Service Los Angeles, CA 323-733-1236 universitytirecenter.com/ ★ 4.6 / 5.0 79 Verified Reviews ♥ 45 Customer Favorites</p>	<p> Vehicle serviced -One tire balanced -One tire mounted</p>
<p>03/23/2026</p>		<p>California Motor Vehicle Dept. Anaheim, CA</p>	<p>Title issued or updated -Loan or lien released</p>
<p>04/01/2026</p>		<p>Damage Report</p>	<p> TOTAL LOSS VEHICLE -Vehicle declared a total loss by an insurance company -Collision damage reported</p> <div data-bbox="873 1283 1507 1388" style="border: 1px solid #ccc; padding: 5px; margin-top: 10px;"> <p>There are many reasons an insurance company will declare a vehicle a total loss. Have this vehicle inspected by a qualified technician before you buy. Learn More</p> </div>
<p>05/19/2026</p>		<p>Damage Report</p>	<p> Damage reported: minor to moderate damage -Damage to right front -Damage to front</p> <div data-bbox="846 1541 1256 1701" style="border: 1px solid #ccc; padding: 10px; margin-top: 10px;"> <p style="text-align: center;">Damage Severity Scale</p> <p style="text-align: center;">  </p> <p style="text-align: center;"> Minor Moderate Severe </p> </div>

CARFAX HAS THE MOST ACCIDENT & DAMAGE INFORMATION



06/18/2026

Auto Auction

Vehicle sold

06/18/2026

Damage Report



SALVAGE TITLE/CERTIFICATE ISSUED

This vehicle's oil change history, as reported to CARFAX, follows the manufacturer's recommendation. Track your service history for free at carfax.com/service.

Have Questions? Consumers, please visit our Help Center at www.carfax.com. Dealers or Subscribers, please visit our Help Center at www.carfaxonline.com.



Glossary

Accident Indicator

CARFAX receives information about accidents in all 50 states, the District of Columbia and Canada.

Not every accident is reported to CARFAX. As details about the accident become available, those additional details are added to the CARFAX Vehicle History Report. CARFAX recommends that you have this vehicle inspected by a qualified mechanic.

CARFAX Well Maintained - Regular Oil Changes

CARFAX identifies a "Well Maintained - Regular Oil Change" vehicle as having a regular oil change history when all its recommended oil changes, based on the vehicle's maintenance schedule, have been reported to CARFAX. CARFAX uses the manufacturer's schedule and assumes normal driving conditions. When an oil change schedule is not available, CARFAX may analyze reported service events to determine what is typical for the same make and model vehicle. Dealers and service shops may publish different recommended service schedules.

Damage Indicator

Damage can be a result of many different types of events. Examples include contact with objects (other cars, trees, traffic signs, road debris, etc), vandalism, or weather-related events. Not every damage event is reported to CARFAX. As details about the damage event become available, those additional details are added to the CARFAX Vehicle History Report. CARFAX recommends that you have this vehicle inspected by a qualified mechanic.

- This CARFAX Vehicle History Report is based only on information supplied to CARFAX and available as of 6/23/26 at 7:50:22 AM (CDT). Other information about this vehicle, including problems, may not have been reported to CARFAX. Use this report as one important tool, along with a vehicle inspection and test drive, to make a better decision about your next used car.

Damage Severity

Damage events result in one of the following severity levels:

- Minor: Generally, minor damage is cosmetic (including dents or scratches), may only require reconditioning, and typically does not compromise a vehicle's operation and/or safety.
- Moderate: Moderate damage may affect multiple components of the vehicle and may impair the vehicle's operation and/or safety.
- Severe: Severe damage usually affects multiple components of the vehicle and is likely to compromise the vehicle's operation and/or safety.

CARFAX recommends getting a pre-purchase inspection at a certified collision repair facility.

First Owner

When the first owner(s) obtains a title from a Department of Motor Vehicles as proof of ownership.

Ownership History

CARFAX defines an owner as an individual or business that possesses and uses a vehicle. Not all title transactions represent changes in ownership. To provide estimated number of owners, CARFAX proprietary technology analyzes all the events in a vehicle history. Estimated ownership is available for vehicles manufactured after 1991 and titled solely in the US including Puerto Rico. Dealers sometimes opt to take ownership of a vehicle and are required to in the following states: Maine, Massachusetts, New Jersey, Ohio, Oklahoma, Pennsylvania and South Dakota. Please consider this as you review a vehicle's estimated ownership history.

Salvage Title

A Salvage Title is issued on a vehicle damaged to the extent that the cost of repairing the vehicle exceeds approximately 75% of its pre-damage value. This damage threshold may vary by state. Some states treat Junk titles the same as Salvage but the majority use this title to indicate that a vehicle is not road worthy and cannot be titled again in that state. The following eleven states also use Salvage titles to identify stolen vehicles - AZ, FL, GA, IL, MD, MN, NJ, NM, NY, OK and OR.

Title Issued

A state issues a title to provide a vehicle owner with proof of ownership. Each title has a unique number. Each title or registration record on a CARFAX report does not necessarily indicate a change in ownership. In Canada, a registration and bill of sale are used as proof of ownership.

Total Loss Vehicle

An insurance or fleet company declares a vehicle a total loss when a claim exceeds approximately 75% of its pre-damage value or if the vehicle is stolen and not recovered. This damage threshold varies by company. These companies typically take possession and obtain the title. Not all total loss vehicles result in a DMV-reported branded title. This may occur when an insurance company's definition of a total loss is different than the state DMV's definition for a branded title or when the owner of the vehicle is a self-insured company, like a fleet or rental company.

Follow Us:



facebook.com/CARFAX



[@CARFAXinc](https://twitter.com/CARFAXinc)



[About CARFAX](#)

CARFAX DEPENDS ON ITS SOURCES FOR THE ACCURACY AND RELIABILITY OF ITS INFORMATION. THEREFORE, NO RESPONSIBILITY IS ASSUMED BY CARFAX OR ITS AGENTS FOR ERRORS OR OMISSIONS IN THIS REPORT. CARFAX FURTHER EXPRESSLY DISCLAIMS ALL WARRANTIES, EXPRESS OR IMPLIED, INCLUDING ANY IMPLIED WARRANTIES OF MERCHANTABILITY OR FITNESS FOR A PARTICULAR PURPOSE.

Customer Signature

Date

Dealer Signature

Date